

ASSEMBLY INSTRUCTIONS

KH5KD, KH6KD, KH7

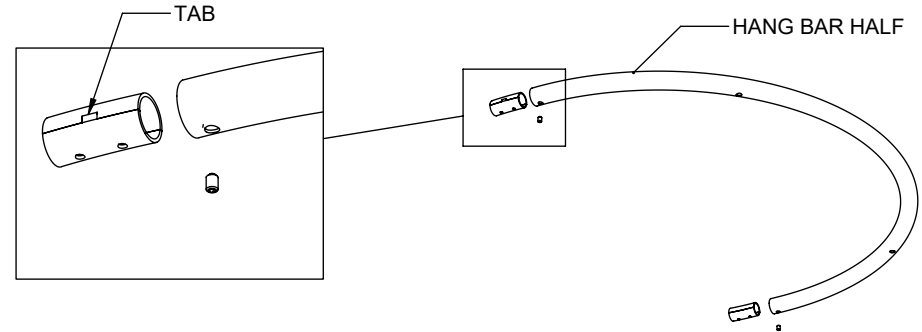
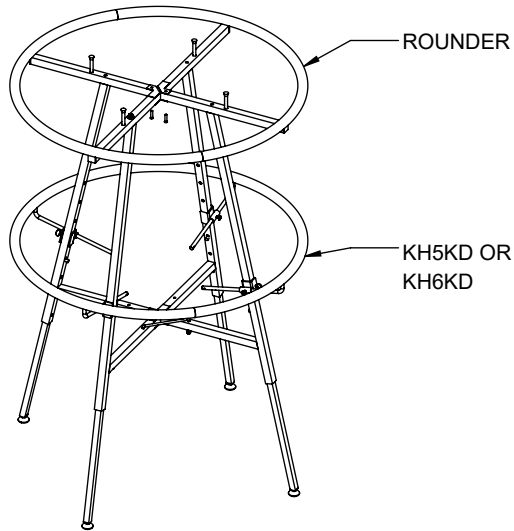

2

- WHILE HOLDING THE CONNECTOR HALVES TOGETHER, INSERT THEM INTO ONE OF THE HANG BAR HALVES AND HAND TIGHTEN A SET SCREW SO IT STAYS IN PLACE.

- REPEAT FOR THE OTHER CONNECTOR.

- **NOTE:** THE CONNECTOR MUST BE INSERTED SO THE TAB IS FACING OUT. THIS WILL ENSURE THE CURVE OF THE CONNECTOR FOLLOWS THE CURVE OF THE HANG BAR.

1

- TAKE A HANG BAR CONNECTOR TOP AND BOTTOM AND JOIN THEM TOGETHER SO THE TAB IS INSERTED INTO THE NOTCH.

- **NOTE:** THEY ARE NOT MEANT TO LOCK TOGETHER.

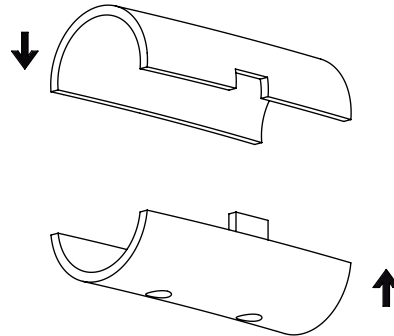

3

- SLEEVE THE REMAINING HANG BAR HALF ONTO THE EXPOSED CONNECTORS AND HAND TIGHTEN THE REMAINING SET SCREWS TO SECURE.

- ONCE ALL 4 SET SCREWS HAVE BEEN STARTED, TIGHTEN WITH THE SMALL ALLEN KEY UNTIL THE HANG BAR FEELS RIGID AND NO SET SCREW IS EXPOSED.

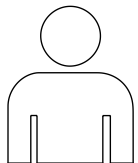
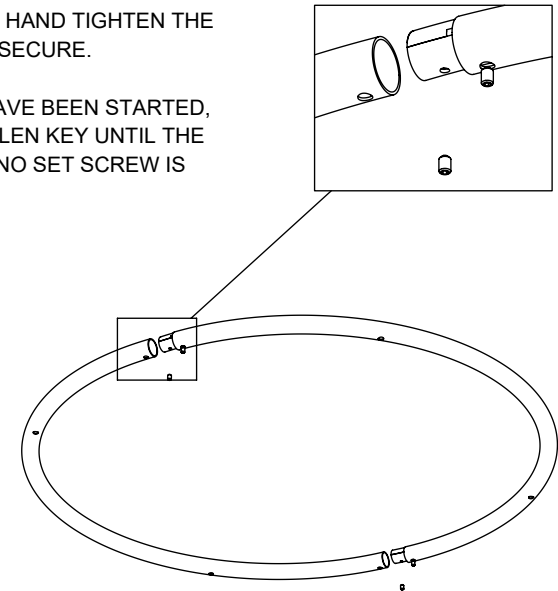

**2 PEOPLE
REQUIRED
FOR
ASSEMBLY**

4

- REMOVE THE UPPER HANG BAR FROM THE ROUNDERS IF ALREADY INSTALLED.

- INSTALL THE KH7 CLAMP ONTO THE UPPER LEG OF THE ROUNDERS FIXTURE AND SECURE WITH THUMB SCREW.

- INSERT THE WIRE MOUNT INTO THE CLAMP AND SECURE WITH SET SCREW.

NOTE: THE POSITION OF THE CLAMP AND MOUNT WILL DEPEND ON THE SIZE OF THE HANG RAIL.

- REPEAT FOR THE REMAINING KH7'S.

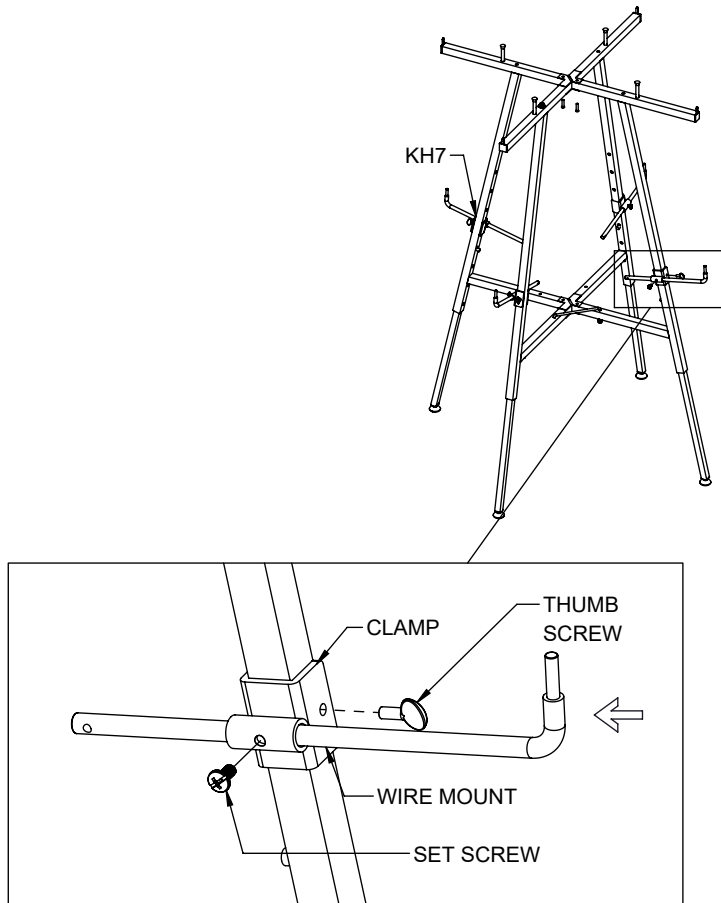

5

- WITH THE CLEARANCE HOLES FACING DOWN, DROP THE ADD ON HANG BAR AROUND THE TOP FRAME OF THE ROUNDERS AND INSTALL ONTO THE KH7 WIRE MOUNTS.

NOTE: THE POSITION OF THE CLAMPS AND WIRE MOUNT MAY HAVE TO BE ADJUSTED TO ALIGN WITH THE CLEARANCE HOLES IN THE ADD ON HANG BAR.

- REINSTALL THE UPPER HANG BAR ONTO THE TOP FRAME OF THE ROUNDERS FIXTURE.

